

Operating and maintenance instructions



WAREMA pergola awning
Perea P70

Der SonnenLichtManager

Original instructions
To be handed over to the opera-
tor.
Please keep for future use.

Table of contents

Table of contents

1	Introduction.....	3
1.1	Information on safety.....	3
1.2	Information on the target group and application of these instructions.....	3
1.3	Explanation of the signal words.....	3
1.4	Basic safety instructions.....	3
2	Product information.....	5
2.1	Intended use.....	5
2.2	Parts description.....	5
2.3	Wind resistance.....	5
2.4	Rain class.....	5
2.5	Declaration of performance.....	5
3	Operation.....	6
3.1	Product with motor.....	6
3.2	Incorrect operation.....	6
4	Maintenance.....	7
4.1	Cleaning and care.....	7
4.2	Maintenance.....	9
4.3	What you should know about awning fabrics.....	10
4.4	Spare parts/repairs.....	10
4.5	Warranty.....	10
5	Dismantling.....	11
6	Troubleshooting.....	12
7	EC Declaration of Conformity.....	13

1 Introduction

1.1 Information on safety

It is important to follow these instructions in the interests of personal safety. Failure to comply with these instructions when operating the product may result in personal injury and/or property damage. Failure to comply with these instructions relieves WAREMA of liability.



Warnings are marked in the instructions with this symbol or a similar symbol.



- Anleitung vor dem Gebrauch des Produktes durchlesen!
- Sicherheits-, Bedien- und Wartungshinweise beachten!
- Include these instructions if you pass the product on to a new owner.
- Keep the instructions until you dispose of the product.

1.2 Information on the target group and application of these instructions

Target group

These instructions are directed at people who operate, care for and/or maintain the product.

The activities listed in the "Maintenance" chapter are only permitted to be executed by a qualified specialist.

Contents

These instructions are an integral part of the following product:
Pergola awning P70

The instructions contain important information on the operation, care and maintenance of this item. They describe how to operate products with WAREMA standard drives. Other drives and special solutions are not dealt with.

Permissible activities

Performing tasks on the product that are not described in these instructions is not permissible. No other alterations, additions, conversions or maintenance work is to be carried out on the product other than as described in these instructions without the written approval of WAREMA.

1.3 Explanation of the signal words



DANGER

Identifies an imminent danger that may result in death or serious injury.



WARNING

Identifies a potential danger that may result in death or serious injury.



CAUTION

Identifies a potential danger that may result in light injury.



NOTICE

Identifies a potential situation that may result in product or property damage.

1.4 Basic safety instructions

The safety instructions and warnings described here are intended to safeguard your health and to protect the product. These instructions must be read carefully and followed.

Damage resulting from inappropriate use or the failure to follow these instructions is not covered by the warranty. Liability will not be accepted for secondary damage.

General operation

The operation of a faulty product may injure persons and/or damage adjacent parts.

- ▶ Only operate the product if it is in technically perfect condition.
- ▶ If the product makes unusual noises or movements, stop using it immediately and inform a qualified specialist.

Possible risk during operation

Incorrect operation can result in personal injury. The movements of the product can lead to crushing of the limbs.

- ▶ While the product is moving, do not reach between the moving parts.
- ▶ Do not reach into openings on the product while operating the product.

Monitoring duty during operation

Failure to monitor the product while it is moving may result in personal injury and property damage.

- ▶ Keep people and animals out of the projection area.
- ▶ Remove obstacles from the projection area.

Introduction

Operation in the event of a power supply failure

An electrically-operated product cannot be operated without power. A lowered/extended product may be subjected to impermissible loads when bad weather fronts pass over and during power failures. This may also result in serious injury to persons and/or damage to the product.

- ▶ Manual emergency operation or an emergency power supply should be considered for windy regions with frequent power failures.

Accessing the operating element (electrically operated product)

The operating element is not intended for children to use. Children are unable to recognize the danger associated with the product. Persons can become injured from careless use.

- ▶ Do not allow children to play with the locally installed control system or operating element.
- ▶ The hand-held transmitter must be kept out of the reach of children.

Operation in wind

The product is only able to withstand the loads associated with the specified wind resistance class.

- ▶ The product must be retracted when the specified wind resistance class is exceeded.
- ▶ The product should not be moved in any other way under heightened wind loads.

Operation in icy conditions/winter (general procedure)

Operating the product at temperatures at or below the freezing point may result in malfunctions and/or damage if the installation and building situation is unfavourable. Moisture on the product due to dew, rain or snow can cause the product to freeze up at low temperatures.

- ▶ Before operating the product, it should be cleared of snow and ice so that it can move freely.
- ▶ Before operating the product, the grooves of the guide rails should be freed of snow and ice so that the product can move freely.
- ▶ Do not operate the product under icy conditions.

Operation in winter (product with control system)

Products operated by means of a control system may start moving at any time and without prior notice. Moisture on the product due to dew, rain or snow can cause the product to freeze up at low temperatures. Operation of the product may cause damage.

- ▶ When using a control system without an ice alarm, the automatic function should be switched off in winter.

Risk of damage to the product

An additional load can damage the product and/or cause it to detach from the wall.

- ▶ It is not permitted to hold onto the product or to lean objects against it.

Freezing of drainage channels in winter

In winter, snowfall may occur. Heat from the sun will begin to melt the snow. In cold and shady areas, melt water will refreeze. Down pipes may freeze and burst open.

- ▶ In areas where temperatures are frequently below freezing, the installation of an antifreeze device (e. g. gutter heating) is recommended in gutters and/or pipes.

Dirty drainage pipes

Gutters may clog with leaves, moss and dirt. This may cause the gutters to overflow when it rains.

- ▶ Installation of a leaf guard is recommended to prevent the accumulation of debris in the down pipe.
- ▶ Gutters without or with an insufficient gradient must be inspected and cleaned more frequently.

2 Product information

2.1 Intended use

The following details apply to the following product: Pergola awning P70

The product is an external, weatherproof, large-area sun shading system that may be used for protection against heat and rain, and for glare control. The product provides shading for private and commercial areas.

Inappropriate use may result in significant danger.

All closures and awnings for external use are designed for a wind load of 1.1 kN/m² when in a retracted state.

The directive entitled "Wind loads for construction of closures and awnings when retracted – Section 5.1.1" defines the positions at which these products can be installed without requiring special precautions [published by the Bundesverband Rollladen + Sonnenschutz e. V. and ITRS Industrieverband Technische Textilien - Rollladen - Sonnenschutz e. V.].

Additional loads on the product in the form of hanging objects or ropes/cables could damage the product or cause it to become detached from the wall and are therefore not permitted. WAREMA will not be liable for any resulting damage.

The intended use also includes observing these instructions and adhering to the service requirements they describe.

2.2 Parts description

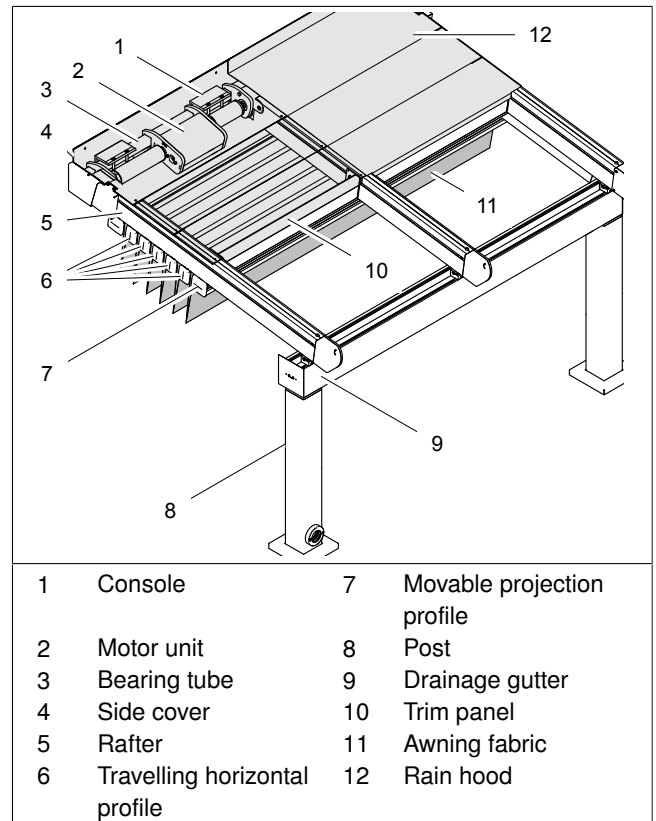

Fig. 1: Parts overview for Perea P70

2.3 Wind resistance



The product reaches the following wind resistance: class 3

Use up to Beaufort 7 is permitted.

Beaufort 7 corresponds to a maximum of 17.4 m/s and is defined as a stiff wind, i. e. inconvenience felt when walking against the wind, whole trees in motion.

2.4 Rain class

The product provides rain protection starting at an inclination angle of 7° (corresponds to the smallest possible angle that can be ordered).

2.5 Declaration of performance



The declaration of performance can be found at (www.warema.de/ce).

3 Operation

INFO

- Only operate the product if it is in technically perfect condition.
- Do not operate a product if it is damaged. Always contact the specialist dealer and protect the product against being operated as agreed with the specialist.



The product can be equipped with additional functions, such as radiant heaters or light rails.

- Before operating the product, read and follow the separate instructions.

3.1 Product with motor



CAUTION

Risk of crushing from failure to exercise care during operation.

Persons who are located within the projection area may be injured.

- Keep the projection area clear of persons.
- Keep children away from the operating elements.

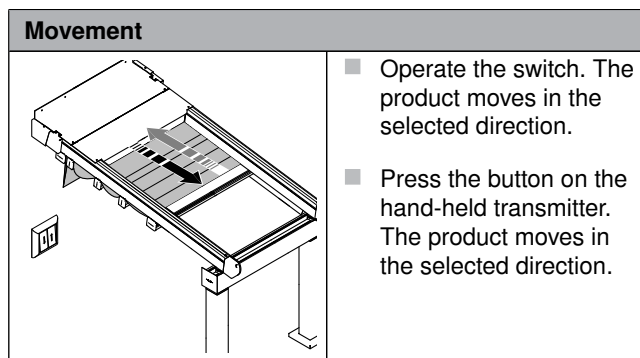

INFO

The product has an upper and lower limit position. The product automatically stops at this point.

The product must always be fully retracted or fully extended.

Operation using a central control unit



NOTICE

Product damage from failure of the control unit!

Under certain external conditions, such as a power failure or a malfunction, the control unit will not be functional. In this case, the control unit will not be able to operate the product and the product may be exposed to extreme loads caused by the weather conditions.

- Set the control to manual operation if you are going to be away for a lengthy period.



INFO

of the motors used are not intended for continuous operation.

The integrated thermal protection switches the motor off after approx. 4 minutes. The product will be ready again for use after 10 to 15 minutes.

- Adjust the control unit in such a way that continuous operation of the motor is not possible.
- Follow the operating and installation instructions of the control unit.

Operation using a hand-held transmitter



INFO

Instructions on how to operate the hand-held transmitter are contained in a separate manual for the hand-held transmitter.

3.2 Incorrect operation

Accessibility of the operating elements

- Never let children play with the operating elements of the product, such as the hand-held transmitter or switch.
- Keep the hand-held transmitter out of reach of children.

Danger of crushing, shearing and entanglement

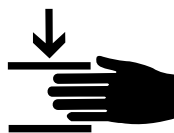

- While the product is moving, keep persons away from the product.
- While the product is moving, do not reach between the moving parts.

Products operated by means of a control unit may start moving at any time and without prior notice. Inform people, including children, who may be located in the vicinity of the product about the danger involved with the product to eliminate the risk.

Operation during a storm

	<p>The product must be retracted by hand before a bad weather front passes over, even if a control unit is being used.</p> <ul style="list-style-type: none"> ■ Retract the product if the recommended wind speed limit is exceeded.
---	---

Operation in cold weather

NOTICE Product damage from forceful operation!

Moisture on the product due to dew, rain or snow can cause the product to freeze at low temperatures.

- Do not use the product under icy conditions. The product may be used again after thawing.
- When using a control unit without an ice alarm, the automatic function should be switched off in winter.

	<ul style="list-style-type: none"> ■ Do not operate the product if it is frozen. ■ Switch off the automatic control mode in winter.
--	---

Cleaning the drainage

INFO If the gutter is installed without an inclination, it must be inspected and cleaned more frequently.

Gutters may clog with leaves, moss and dirt. This may cause the gutters to overflow when it rains. If trees are in the vicinity, it is most efficient to clean the gutter after all of the leaves have fallen in autumn.

In autumn, leaves may have to be removed more frequently, depending on the location of the patio.

	<ul style="list-style-type: none"> ■ Clean out old leaves and dirt that may have collected in the drains (gutter and downpipe).
---	--

4 Maintenance

Proper and regular cleaning and maintenance and the use of original spare parts only are essential for fault-free operation and a long service life.

INFO When performing product maintenance or working in the vicinity of the product, such as when cleaning windows, movement of the product must be prevented.

A monitored, overriding locking mechanism must prevent every kind of operation.

WARNING Risk of injury from operation of the product when it is out of view!

The product may unexpectedly start moving during cleaning or maintenance.

- De-energise the product and secure it against being switched on again.

CAUTION Risk of injury from falling from climbing aid!

Climbing aids (e. g. ladders, scaffolding etc.) may tip over if improperly erected.

- Position climbing aids on level and firm ground.

CAUTION Risk of injury from falling!

There is a risk of falling during maintenance work!

- Take suitable, safe measures to prevent or stop a fall!

4.1 Cleaning and care

Over time, a film of dirt will settle on the surfaces of sun shading products due to environmental influences.

Due to the effects of solar radiation, this contamination may become permanently adhered to the surface coating. These factors reduce the value and, possibly, impair the function of the sun shading product.

To contribute to a long service life of the sun shading product, the surfaces should be cleaned regularly or **at least once a year**.

In certain environments such as in industrial zones, close to heavy traffic and in the vicinity of the sea (salty air), more frequent cleaning may be necessary to protect against surface damage.

Maintenance

Purpose of cleaning and care

The purpose of regular and proper cleaning and care is to retain the value of the product and extend its service life. The purpose of repeatedly cleaning the product is to retain the well-maintained appearance of the building and product.

Result of cleaning



NOTICE

Product damage from incorrect cleaning!

Incorrect cleaning procedures may result in damage to the product or product parts. Surfaces and structures may be permanently altered (e.g. scratches).

- Do not use high pressure washers, steam washers, abrasive sponges, abrasive cleansers, or aggressive cleaning agents or solvents such as alcohol or naphtha.
- Do not use chlorinated cleaning agents on or near the product.

No claims for damage can be raised on the grounds of this cleaning information, as the effectiveness depends on a large number of factors that vary widely from case to case.

The effort required for cleaning and the cleaning results depend on the degree of soiling. It will difficult or possible to restore surfaces that have been exposed to the weather and have not been cleaned over many years to their original state.

General information on cleaning



WARNING

Risk of injury from electric shock in a motorized product!

If an energised component (e.g. motor) is brought into contact with water, a short circuit may occur or electricity may be transmitted.

- Keep water away from energised components.



Tip/recommendation

The WAREMA cleaning glove combined with WAREMA cleaning agent concentrate for sun shading products is ideal for properly cleaning the surfaces.

The WAREMA cleaning agent can be used for metal and plastic surfaces and is certified by the GRM (Gütegemeinschaft Reinigung von Fassaden e.V.) (certification no. 142, 242, 342, 442, 542).



To order, contact your WAREMA dealer.



For further advice and in technical matters regarding cleaning, please contact the Verband Deutscher Sonnenschutzreiniger e.V. (www.vds-sonnenschutz.de).

Preparing cleaning

- When cleaning the product, protect adjacent areas against soiling.

Aids required for cleaning:

- ▶ Whisk broom (soft bristles)
- ▶ Vacuum cleaner (optional)
- ▶ Bucket
- ▶ Low-calcium water (recommendation)
- ▶ Cleaning agent (pH-neutral)
- ▶ Microfibre cloth or sponge
- ▶ Cotton cloth



INFO

Step-wise cleaning from back to front

- 1 Rain hood
- 2 Fabric guide
- 3 Awning fabric (as needed)
- 4 Front rail
- 5 Cross sections
- 6 Drainage gutter
- 7 Poles

Performing rough cleaning

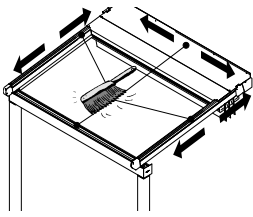

- Clean the complete product of loose dirt (e.g. dust,). Do not forget the opening of the guide for the curtain. A whisk broom/ broom or vacuum cleaner can be used for this.

or

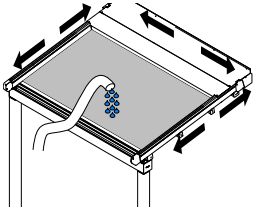

- If the product is outside (outdoors), alternatively rinse off loose dirt with fresh water with a low water pressure.

Performing detailed cleaning

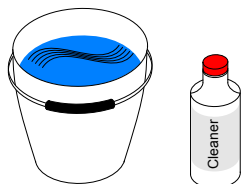

- Prepare the bucket with water and cleaning agent. Note the dosing quantities specified by the cleaning agent manufacturer.
- Moisten the microfibre or sponge.

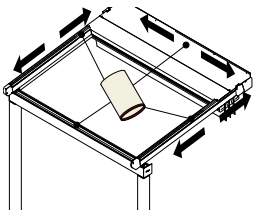

- Clean the product components with a wiping motion. Repeat the procedure if necessary due to the degree of soiling.
- Clean the drainage gutter and drainage pipe to remove any blockages, e. g. due to leaves.

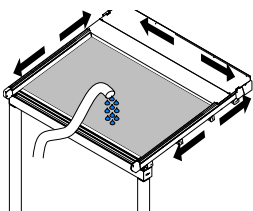

- Remove the detached soiling before drying.

Drying the product

- extend the product into the lower limit position.



INFO

To avoid calcium edges around dried water droplets, the surfaces of the product can be rubbed dry using a microfibre cloth or cotten cloth.

Inspecting the product during cleaning

- Operate the product and inspect the operating elements for visible wear and damage (visual check).
- Check the mounting substructure for damage (visual check).



INFO

Wear and damage to the operating element or product as well as damage to the mounting substructure may impair the product and result in secondary damage.

- Take the product out of service.
- Have any damage repaired by a qualified specialist.

4.2 Maintenance



CAUTION

Risk of injury from lack of product knowledge!

- Have service tasks performed by a qualified specialist.



The product must be maintained at least once a year.

The maintenance tasks may only be performed by a qualified specialist. We recommend signing a service contract.

The WAREMA warranty becomes invalid if the unit is not maintained properly at least once a year.



WARNING

Risk of injury through irregular maintenance!

Operating safety may be seriously impaired and the product may fail. Persons may become injured from contact with damaged parts.

- Have the product checked regularly by a qualified specialist for signs of wear and damage, e.g. to electrical lines.
- Do not operate products in need of repair.

- Check the product for visible wear and damage. If necessary, make a recommendation to the owner.
- Check that the fixation of the bearing elements (e.g. consoles, guide elements) is properly seated. If necessary, make a recommendation to the owner.
- Perform a functional check and check the limit positions of the product. Adjust the setting of the limit positions if necessary (see the installation instructions and/or setting instructions).

Maintenance



INFO

To retain the warranty, maintenance must be performed by a qualified specialist according to the WAREMA maintenance checklist.

The maintenance checklist is available from your specialist dealer or can be requested from WAREMA.

4.3 What you should know about awning fabrics

Technical fabrics may exhibit certain characteristics due to production and sizing that may appear to the operator to be "faults".

The blemishes described below have no influence on the usability and durability of the awning fabric [excerpt from the Guideline for the Evaluation of Preassembled Awning Fabrics – published by the ITRS Industrieverband Technische Textilien Rollladen - Sonnenschutz e. V.]:

Wrinkles and folding lines

Wrinkles can be produced when the fabric is assembled (cut and sewn) and when it is folded. Surface effects (shifts in pigmentation) can occur in the wrinkles. When viewed against the light, these resemble dirty marks (especially on light-coloured fabric).

Chalk lines

These are light stripes of the impregnating material on the fabric surface. They result from handling the fabric during production and assembly of the units. Although the fabric is handled with special care, these effects cannot be fully avoided in dark fabrics.

Waviness in the seams and fabric panels

As the fabric is wound onto and off of the shaft, it is tightened more at the borders, seams and panels than between the seams. The resulting tension in the fabric can lead to waviness (e. g. waffle or fishbone patterns) that "digs" into the fabric. The waves are visible when the unit is open.

Waffling

Because of the production method, waffling may form under certain weather conditions and in certain fabric sizes. This effect is more visible in unfavourable lighting conditions. The formation of waffling is accelerated and enhanced through wetness (humidity, rain). If a fabric that has been "softened" in this way is retracted, waffling and wrinkles can become particularly pronounced.

Weave flaws

Spinning of the yarns as well as warping in the weaving mill and the weaving process itself is executed under tension. The yarn may break. This will lead to knots. Irregular thread thicknesses are seen as light areas or burls in the fabric.

4.4 Spare parts/repairs



CAUTION

Personal injury resulting from inappropriate repairs!

To be able to perform work on the product safely, it is necessary to be familiar with its functions and structure. A lack of appropriate product knowledge may lead to dangerous situations.

- The product should only be repaired by a qualified specialist.



INFO

To ensure that your product will operate properly on a continuous basis and to avoid changing its approved status, use original spare parts only. Contact your WAREMA specialist dealer if necessary.

4.5 Warranty

Subject to the statutory period of limitation for warranty claims. This requires regular maintenance. The warranty does not include wear parts or optical changes in line with the type of material used (e. g. bleaching of surfaces caused by UV rays).

5 Dismantling



CAUTION

Risk of injury due to incorrect dismantling!

A lack of appropriate knowledge when dismantling the product can lead to injuries and/or damage to the adjacent parts.

- Have the units dismantled by a qualified specialist.

Dismantling of the product must be undertaken by a qualified specialist. Ask WAREMA for any missing documents before commencing maintenance.



WARNING

Electric shock!



When working in the immediate vicinity of potentially live parts, such as electrical lines, contact may result in an electric shock.

- De-energise the product and secure it against being switched on again.

Disposal

Should the product no longer be required, ensure that it is disposed of correctly in accordance with the relevant regulations.



Components identified in this manner should not be disposed of with the household waste.

6 Troubleshooting



INFO

- Problems described here without a reference to a qualified specialist or certified electrician may be rectified independently.
- All other problems described here are only to be dealt with by a qualified specialist or certified electrician.

Fault: The motor is not functioning			
	Cause	Remedy	Note
	The thermal protection switch of the motor has triggered	Wait 10 to 15 minutes and then try again.	
	A higher-level control command is present	Wait for on/off delay and then try again.	
	No voltage is applied.	Check the power supply.	Have checked by a certified electrician.
	Motor is faulty	Replace the motor.	Replacement by a qualified specialist

Fault: The product does not move to the desired limit position			
	Cause	Remedy	Note
	The motor limit positions are incorrect	Readjust the motor.	Adjustment by a qualified specialist

7 EC Declaration of Conformity

The product:

Pergola awnings

Type:

Perea P70

Purpose:

External textile sun shading system

Meets the provisions of **Machinery Directive 2006/42/EC** in the case of motor drives.

In particular, the following harmonised standards were used:

DIN EN 13561

Awnings - Performance requirements including safety.

DIN EN 60335-2-97

Household and similar electrical appliances - Safety - Part 2-97: Particular requirements for drives for rolling shutters, awnings, blinds and similar equipment

Person in charge of the compilation of the technical documents: Elke Granzer; for address, see manufacturer.

Manufacturer:

WAREMA Renkhoff SE
Hans-Wilhelm-Renkhoff-Str. 2
97828 Marktheidenfeld
Germany

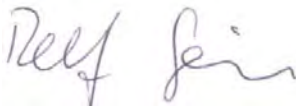

ppa. Ralf Simon

General Management, Research and Development

i. A. Elke Granzer

Technical Coordination R & D

Marktheidenfeld, May 2018

